



**anchor™**

True Economy Lies in Quality



# Surgical Needles

All needles in this catalog  
are to scale.



FDA MDR No.: 05148

 pmc.ph

 pmc.ph

## Proper Needle Use

- **DO NOT CLAMP HOLDER DIRECTLY ON THE EYE**
- **DO NOT GRASP NEEDLE POINT**
- **DO NOT REUSE BENT OR DAMAGED NEEDLES**

Improper surgical technique in the use of a suturing needle may result in needle breakage. Small needle holders should be used on fine gauge needles and heavy holders on heavy gauge needles to avoid undue stress and breakage. As the weakest part of a needle is the eye and the point, Anchor needles are manufactured with a flat area on the shank to facilitate proper clamping and to prevent turning.

Apply holder on flat part about 1/4 of length from the eyed end, do not clamp holder directly on the eye.

When withdrawing needles, clamp on shank about 1/4 length from the point, do not grasp needle point.

Examine needle carefully after each use. If needle becomes bent or damaged during use, withdraw and discard needle.



**Do not reuse bent or damaged needles!**

Note: In order to view or print the actual size of needles,  
set page and printer to A4 and "Do not Scale".

## SURGICAL NEEDLES

## SURGICAL NEEDLES

### TONSIL, DAVIS

1845



3/8 Circle

1849



1/2 Circle



TAPER  
POINT

### REGULAR SURGEON'S

3/8 CIRCLE

1822

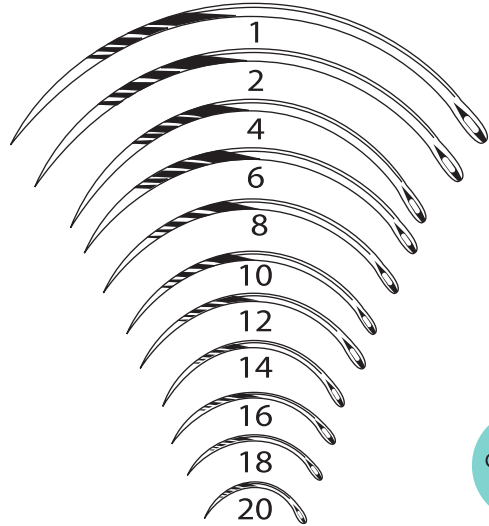

CUTTING  
EDGE

### TROCAR

1/2 CIRCLE

1826

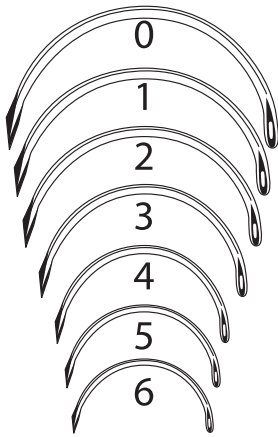

TROCAR  
POINT

### REGULAR SURGEON'S

1/2 CIRCLE

1834

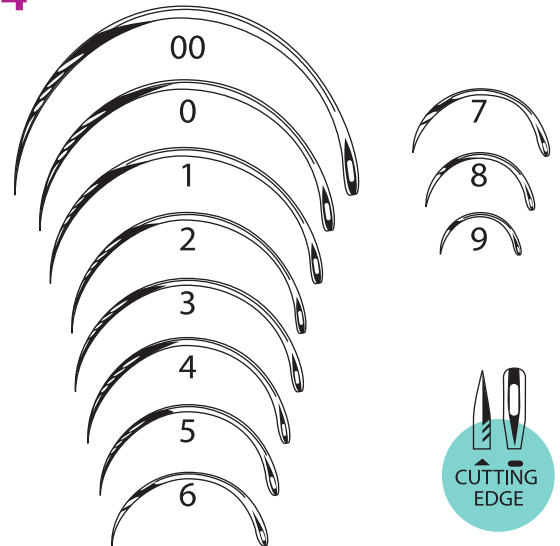

CUTTING  
EDGE

### TROCAR

3/8 CIRCLE

1836

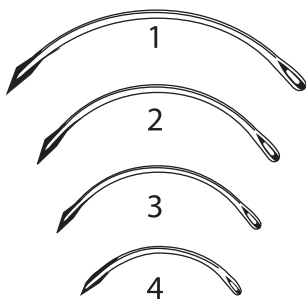

TROCAR  
POINT

**SURGICAL NEEDLES**

**SURGICAL NEEDLES**

**MURPHY INTESTINAL** 1/2 CIRCLE  
**1825**

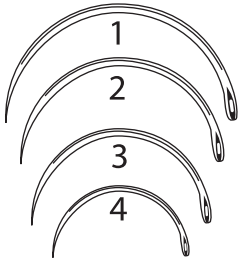

**MAYO INTESTINAL** 3/8 CIRCLE  
**1837**

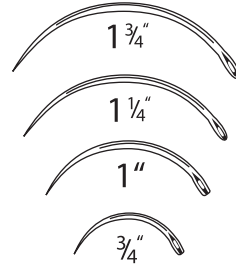

**REGULAR SURGEON'S** 1/2 CURVED  
**1821** non-sterile only

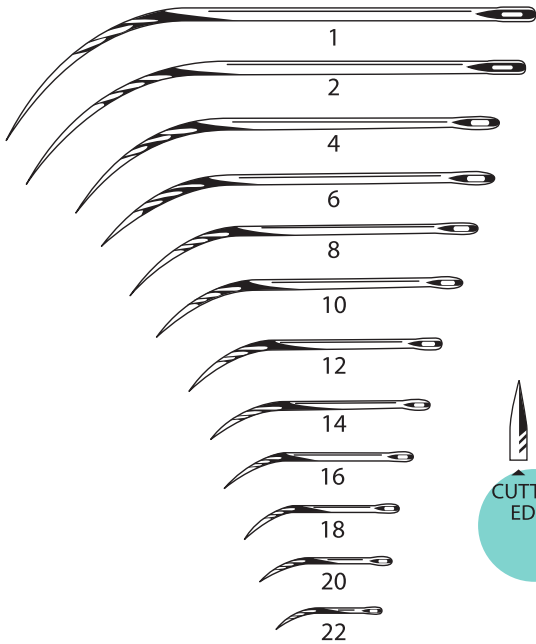

**MAYO** *INTESTINAL Straight*  
**1828**

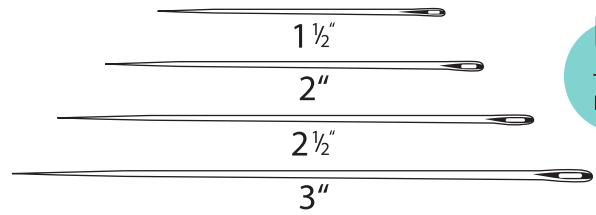

**MCGOWAN** 1/2 CIRCLE *Heavy Gauge*  
**1859**

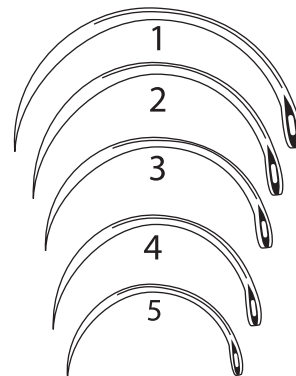

**SURGICAL NEEDLES**

**SURGICAL NEEDLES**

**MARTIN UTERINE** 1/2 CIRCLE Heavy Gauge

**1860**

also used for orthopedics

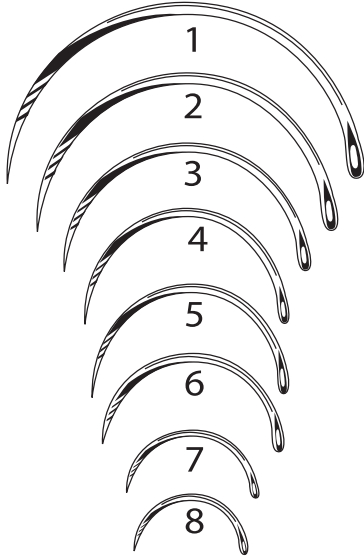

**MAYO** 1/2 CIRCLE

**1824**

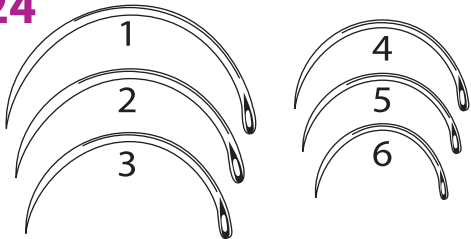

**MAYO INTESTINAL** 1/2 CIRCLE

**1823**

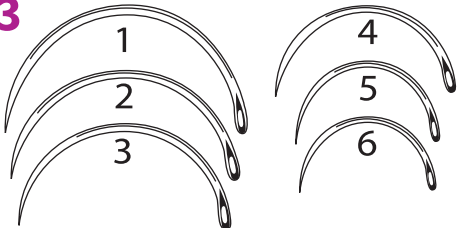

**KING** 3/8 CIRCLE

**1841**

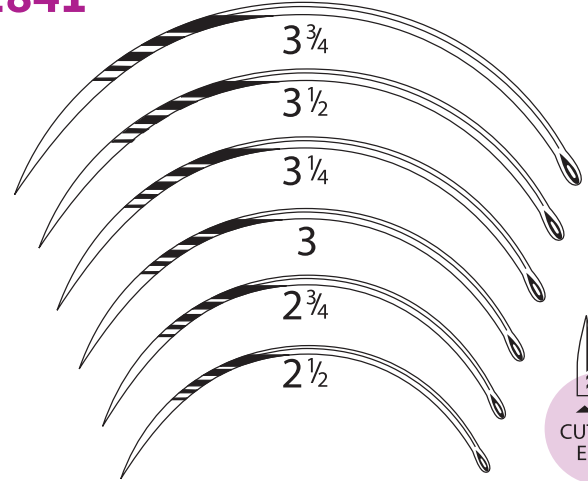

**LANES CLEFT PALATE**

**1844** 1/2 Circle

**1848** 3/8 Circle

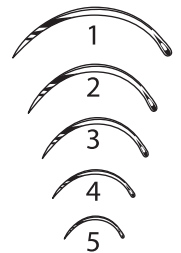

**LOOPUYT'S**

**1846**

(non sterile only)

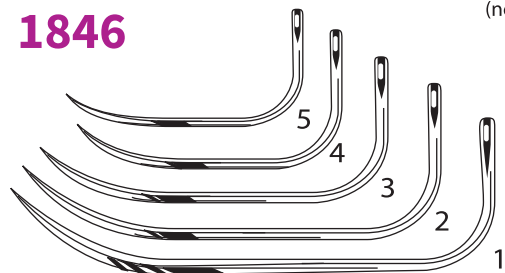

## SURGICAL NEEDLES

### KEITH

Straight

1827

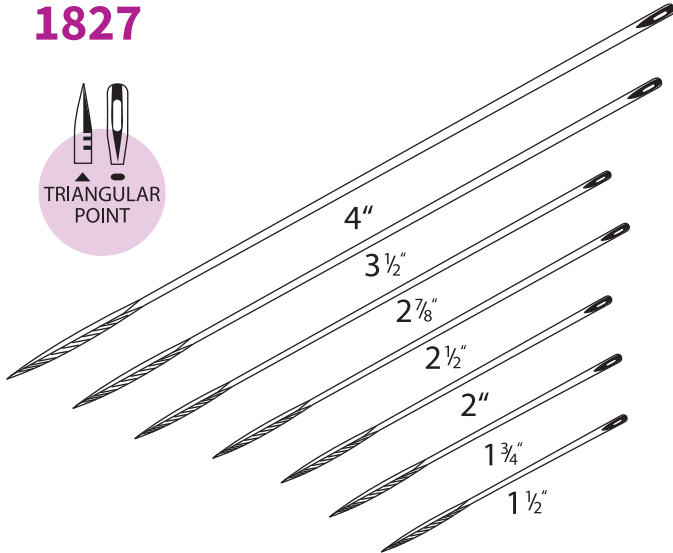

### KIDNEY

1/2 Curved

1838

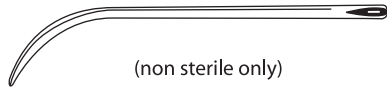

### KIDNEY

1/2 Circle

1839

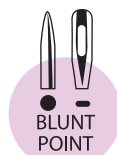
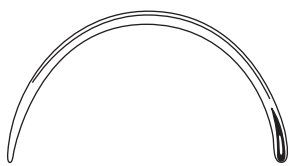

### KIDNEY

straight (1840)

1840



## SURGICAL NEEDLES

### HERNIA 1/2 Circle

1829

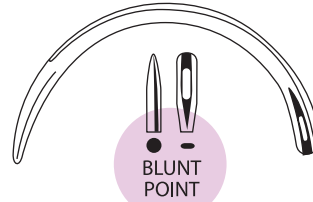

### KOONTZ 1/2 Circle

1847



(1824-6, 1849 also used for hernia)

### INTESTINAL

STRAIGHT *fine*

1843

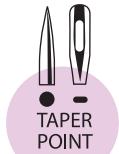
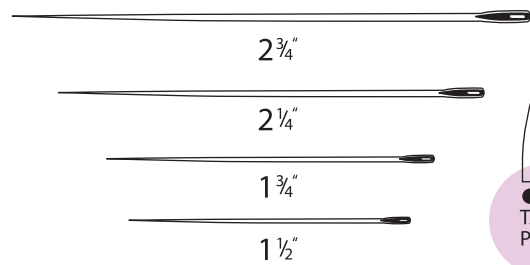

### FINE INTESTINAL

1/2 CIRCLE *fine*

1850

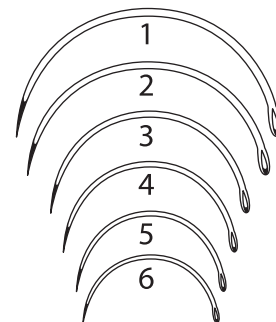

## SURGICAL NEEDLES

### FISH HOOK

**1853-3**

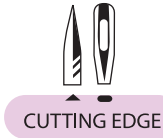

### FISTULA

**1/2 CIRCLE** heavy gauge

**1832**

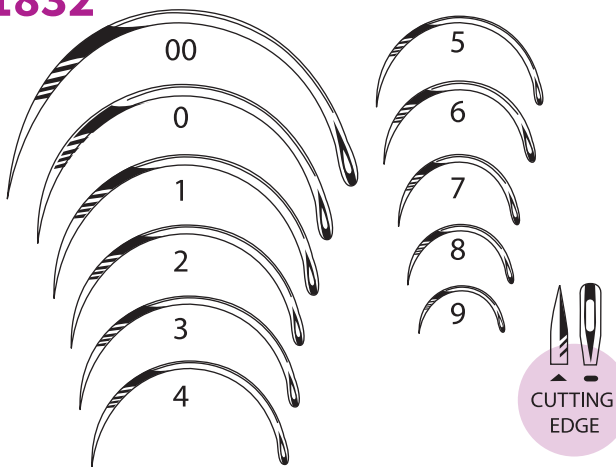

### FRENCH SPRING EYE

**1/2 CIRCLE**

**1861**

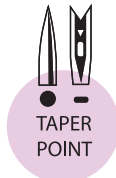
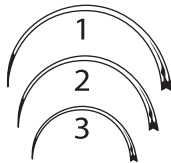

### HAGEDORN

**STRAIGHT** flat body

**1852**

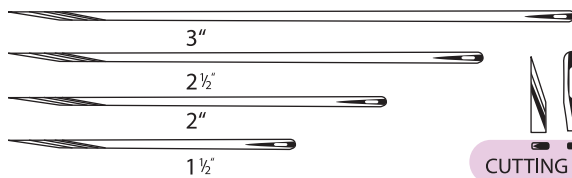

## SURGICAL NEEDLES

### EYE

**1830** 3/8 Circle

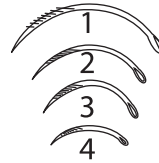

**1831** 1/2 Circle

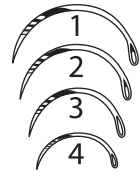

**1833** 1/2 Circle

(1833-3, 1833-4 also used for dura)

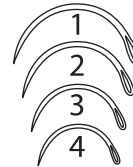

**1857** Jameson Strabismus

(non-sterile only)

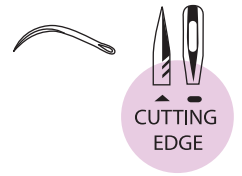

### FERGUSON

**1/2 CIRCLE**

**1842**

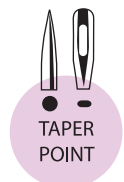
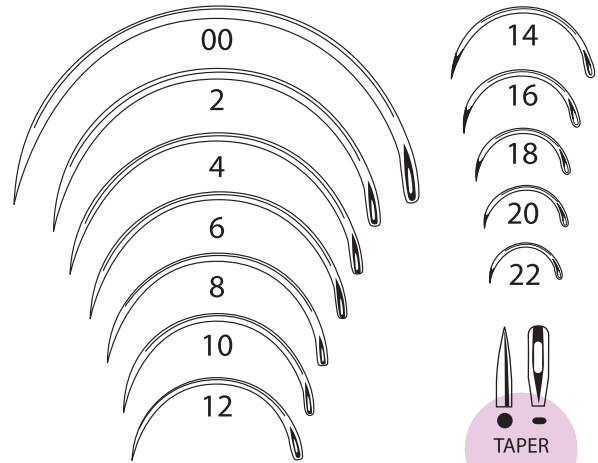

(1842-20, 1842-22 also used for dura)

## SURGICAL NEEDLES

## Economy and Savings

### ABSCISSION

3/8 CIRCLE

1851

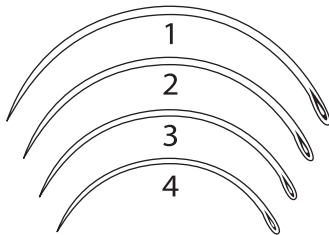

### BUNNELS

STRAIGHT

1854

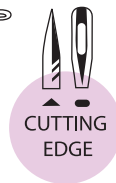
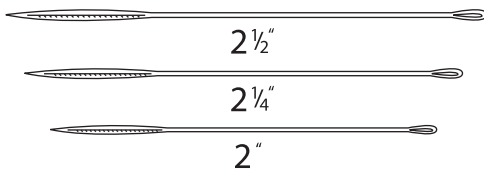

### CERVIX

3/8 CIRCLE

1835

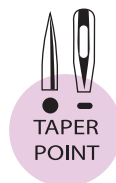
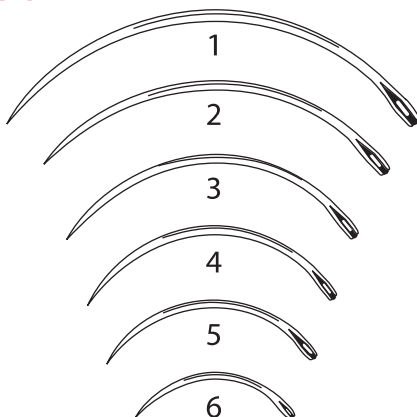

TRUE ECONOMY LIES IN QUALITY. ANCHOR STAINLESS STEEL NEEDLES ASSURES BOTH, QUALITY AND ECONOMY.

Discriminating surgeons prefer ANCHOR needles because they satisfy the most exacting requirements of their profession.

Hospitals and institutions discovered the great economy in procuring ANCHOR needles, saving expensive suture material and reducing the quantity of needles purchased in as much as ANCHOR needles can be re-sterilized and reused innumerable times.

ANCHOR needles offers a wide range of impressive features:

- Highest quality stainless steel exposed to sophisticated heat treatment; needles are flexible, but tough and sturdy.
- Each ANCHOR needles is individually ground and inspected to assure a keen cutting edge and point and a large, smooth, burr-free eye. This permits easy threading of suture and prevents suture fraying.
- Each ANCHOR needle is electropolished to assure a point of maximum sharpness allowing greatest ease of penetration and smoothness of passage through tissue.
- ANCHOR needles retain keen cutting edges and points, remain clean and bright inspite of frequent sterilization - will not rust or become discolored.
- ANCHOR needles are well-balanced, with uniformly flat, strong eyes; will not turn in needle-holder.
- The reverse cutting edge type ANCHOR needles have the flat surface of the triangular shape inside of the needle-curve, to minimize trauma.

ANCHOR PRODUCTS COMPANY takes pride in its worldwide reputation as a leading manufacturer of high-quality stainless steel surgical needles for 60 years. Anchor needles have long proven their excellence in thousands of hospitals in the United States and abroad, and are the preferred choice of highly trained surgical-care teams. In craftsmanship, as in surgery, techniques can make the difference; techniques that only human hands can provide. Anchor needles must meet the most exacting and precise product-specifications under strict supervision and verification, complying with rigid quality control procedures. In addition to surgical needles, Anchor offers a wide range of other O.R. related products, such as:

- Eyeless Surgical Needles (atraumatic needles) with sutures attached, in sterilized packaging.
- Custom Needle Kits.
- Reusable stainless steel Sterilizing Rack and Box.

# WARNING!

Are you paying for the real Anchor?



Don't be deceived by this difference...



Genuine



Imitation



Comparison

Genuine		Imitation
sealed in tamper-proof box	✓	open paper envelop only
combination of purple and white	✓	violet color
barcoded with MDR	✓	ordinary sticker
Progressive Medical Corporation	✓	fly by night company
Anchor Products Company, USA	✓	questionable
guaranteed superior	✓	questionable
		PACKAGING
		COLOR
		LABELS
		DISTRIBUTOR
		MANUFACTURER
		QUALITY



**anchor™**  
True Economy Lies in Quality



Exclusive Philippine Importer and Licensee:



Distributed by:

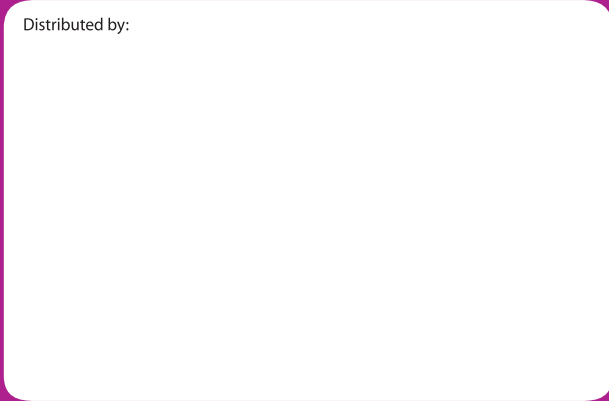

CAT. NO. 2 Rev 9/12/19

**BEWARE OF IMITATIONS!**

“True Economy Lies in Quality”  
Be sure you're enjoying it.



© Copyright PMC

